

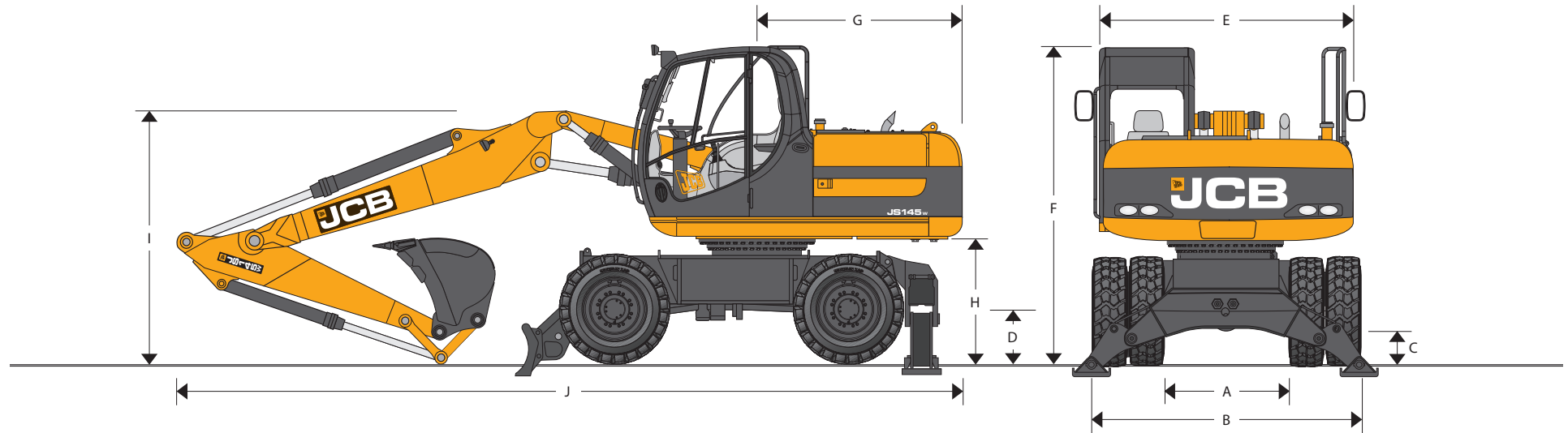

MAX. OPERATING WEIGHT: 15145 kg (33389 lb) ENGINE POWER: 92 kW (125 hp)



### STATIC DIMENSIONS

Dimensions in millimetres (ft-in)		
A	Internal width between dual wheels	1330 (4-4)
B	External width over dual wheels	2490 (8-2)
C	Ground clearance	350 (1-2)
D	Height to axle centre line dual wheels	498 (1-7)
	Height to axle centre line single wheels	519 (1-8)
E	Overall width (handrail removed)	2480 (8-2)
F	Height over cab	3155 (10-4)
G	Tail length	2050 (6-9)
H	Clearance under counterweight	1240 (4-1)

#### Monoboom 4.7m (15ft 4in)

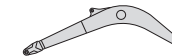

Dipper length		2.10m (6ft 11in)	2.50m (8ft 2in)	3.0m (9ft 10in)
I	Transport boom height	mm (ft-in)	3040 (10-0)	3040 (10-0)
J	Transport length	mm (ft-in)	7580 (24-10)	7600 (24-11)

#### Triple articulated boom 5.0m (16ft 4in)



Dipper length		2.10m (6ft 11in)	2.50m (8ft 2in)	3.0m (9ft 10in)
I	Transport boom height	mm (ft-in)	3040 (10-0)	3040 (10-0)
J	Transport length	mm (ft-in)	7310 (24-0)	7650 (25-1)

## CHASSIS OPTIONS

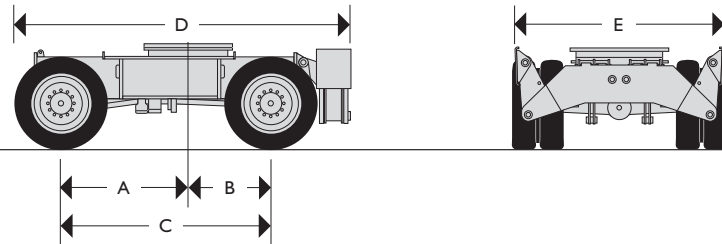

## Dimensions in millimetres (ft-in)

A	Centre of slew ring to front axle	1500 (4-11)
B	Centre of slew ring to rear axle	1000 (3-3)
C	Wheelbase	2500 (8-2)
D	Length including rear stabilizers	3950 (12-11)
E	Width over stabilizers (raised)	2480 (8-1)

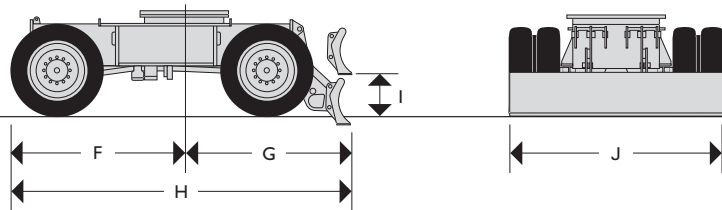

## Dimensions in millimetres (ft-in)

F	Centre of slew ring to face of front tyre	1990 (6-6)
G	Centre of slew ring to rear dozer blade (lowered)	2090 (6-10)
H	Length including rear dozer blade (raised)	4050 (13-3)
I	Ground level to bottom of rear dozer blade (raised)	450 (1-6)
J	Dozer blade width	2480 (8-1)

## CHASSIS OPTIONS

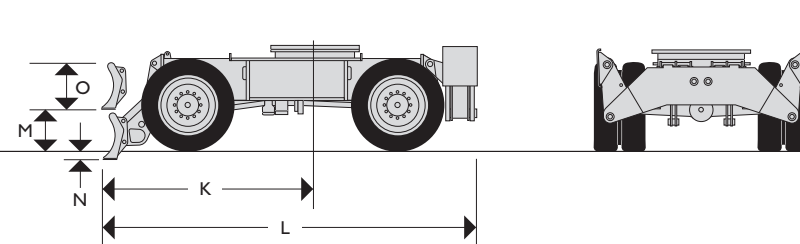

## Dimensions in millimetres (ft-in)

K	Centre of slew ring to front dozer blade (lowered)	2530 (8-3)
L	Length including stabilizers and dozer blade (raised)	4460 (14-7)
M	Ground level to bottom of front dozer blade (raised)	450 (1-6)
N	Dozer blade dig depth	130 (0-5)
O	Dozer blade height	500 (1-8)

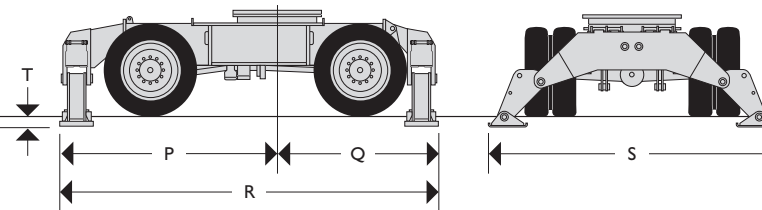

## Dimensions in millimetres (ft-in)

P	Centre of slew ring to front stabilizers	2520 (8-3)
Q	Centre of slew ring to rear stabilizers	1960 (6-5)
R	Length including front and rear stabilizers	4480 (14-8)
S	Width over stabilizers (lowered)	3550 (11-8)
T	Stabilizer lift height	130 (0-5)



## ENGINE

<b>Model</b>	Isuzu 4JJ1X European Tier 3 emissions compliant.
<b>Type</b>	Water cooled, 4-stroke, 4-cylinder in-line, direct injection, turbocharged diesel.
<b>Rated power (ISO14899 (SAE J1995))</b>	92kW (125hp) at 2200rpm.
<b>Piston Displacement</b>	2.99 litres.
<b>Injection</b>	Electronic injection.
<b>Air Filtration</b>	Dry element with secondary safety element and in cab warning indicator.
<b>Cooling</b>	Large capacity radiator.
<b>Starting system</b>	24 volt – 4kW.
<b>Batteries</b>	2 x 12 volt Heavy Duty.
<b>Alternator</b>	24 volt 50 amp.
<b>Refuelling pump</b>	Electric type.

## SWING SYSTEM

<b>Drive train</b>	Axial piston motor and planetary reduction final drive.
<b>Swing brake</b>	Hydraulic braking plus automatic spring applied disc type parking brake.
<b>Swing speed</b>	13.4RPM
<b>Swing gear</b>	Large diameter, internally toothed fully sealed grease bath lubricated.

## CHASSIS

<b>Structure</b>	High strength flanged 'u' section.
<b>Chassis Options:</b>	
<b>Dozer Blade</b>	Front or rear pin mount.
<b>Stabilisers</b>	Front or rear pin mount, independently operable – plus combinations.
<b>Grab Stowage</b>	Heavy duty, pin mounted stowage bar.
<b>Transmission</b>	Hydrostatic drive via piston motor and powershift transmission.
<b>Travel speed</b>	Creep speed 3.3kph Low ratio 14kph High ratio 30kph (19mph)
<b>Drawbar pull</b>	86.6 kN
<b>Axles</b>	Four wheel drive. Front steering axle oscillates for rough ground mobility.
<b>Axle load capacity</b>	26 tonnes
<b>Axle oscillation</b>	+/- 8.5 degrees
<b>Ground clearance</b>	350mm
<b>Steering</b>	Fully hydraulic system.
<b>Turning radius</b>	5.45m (17ft 10in)
To outside of tyres	
To outer edge of front mounted dozer blade	6.06m (19ft 10in)
<b>Brakes</b>	All hydraulic, dual circuit brake system.
<b>Parking Brake</b>	Built into the transmission.
<b>Gradability</b>	35° 70% max. continuous.

## EXCAVATOR END

Monoboom available along with a choice of dipper lengths to suit the requirements of reach, dig-depth, loadover height, tearouts and site versatility. Reserve strength is built into the fully welded structures for hydraulic hammer and other arduous operations. Fabricated bucket tipping links are provided with a choice of lift points. Strong, durable construction, large cross sections and multi plate fabrications to withstand high stress applications. The 4.70m (15ft 4in) boom is designed to ensure the optimum digging envelope when matched with the three dipper lengths. Low maintenance bronze alloy bushes with graphite plugs are fitted to boom base and boom to dipper pivots resulting in 1000 hour greasing intervals at these points.

## EXCAVATOR END – T.A.B.

Triple articulated boom available along with a choice of dipper lengths to suit the requirements of reach, dig-depth, loadover height, tearouts and site versatility. Reserve strength is built into the fully welded structures for hydraulic hammer and other arduous operations. Fabricated bucket tipping links are provided with a choice of lift points. Strong, durable construction, large cross sections and multi plate fabrications to withstand high stress applications. The boom is designed to ensure the optimum digging envelope when matched with the three dipper lengths.



## MAIN HYDRAULIC SYSTEM

<b>System</b>	Load-sensed hydraulic system with twin variable flow piston pumps providing flow-on-demand for maximum efficiency.
<b>Main pumps</b>	2 variable displacement axial piston type
Maximum flow	2 x 128 l/min (31 UK gpm)
Main circuit pressure	314 bar (4555 lb/in <sup>2</sup> )
With power boost	343 bar (4975 lb/in <sup>2</sup> )
<b>Servo pump</b>	Gear type
Maximum flow	22 l/min (5 UK gpm)
Servo pressure	40 bar (580 lb/in <sup>2</sup> )
<b>Optional Circuits:</b>	
<b>Hammer</b>	Includes automatic engine speed setting and return filter.
Maximum flow	138 l/min (30 UK gpm)
Maximum pressure	314 (343) bar (4555/4975 lb/in <sup>2</sup> ) (pre-set to 180 bar (2610 lb/in <sup>2</sup> ))
<b>Grab operation</b>	
Maximum flow	138 l/min (30 UK gpm)
Maximum pressure for grab ram operation	314 (343) bar (4555/4975 lb/in <sup>2</sup> )
<b>Low Flow Pipework</b>	Two options available, one with 20L/min (4 UK gpm) flow and a second with an adjustable flow of 27-45L/min (6-10 UK gpm).
<b>Hydraulic Cylinders</b>	Hardened, chromed piston rods and end cushioning on boom, dipper and bucket crowd cylinder.
<b>Filtration</b>	
In tank	150 micron, suction strainer.
Main return line	10 micron, fibreform element.
Pilot line	10 micron, paper element.
Plexus by pass line	1.5 micron paper element.
Hydraulic hammer return	10 micron, reinforced microform element.
<b>Cooling</b>	
Worldwide cooling is provided by a single faced engine water, hydraulic oil and intercooler with swing out air conditioning condenser for easy cleaning.	

## TYRES

<b>Twins</b>	10.00 x 20 tyres (16PR) with spacer ring.
<b>Single</b>	18R x 19.5 tyres (Radials).

## CAB

Excellent digging, loading and positioning visibility results from the careful design of front, side and roof lights. All screens are tinted to improve in cab conditions.

Fully opening front screen is very smooth to operate and as the lower screen is stored within the top screen frame it makes complete front screen opening easy, fast and convenient.

Fresh air ventilation available from opening door window, opening slot in front screen and fully opening front screen.

Parallelogram wash wiper for upper screen ensuring good wiped area for maximum visibility. Wiper motor is fitted in the left hand side of the roof screen so as not to affect bucket visibility when loading. Optional lower screen wiper available.

Fresh air ventilation and heater with windscreen demister. Infinitely variable blower speed, temperature and recirculation control.

Climate control. Fully adjustable deluxe suspension seat with arm rest adjustment and backrest recline. Radio with digital tuner fitted into the roof lining for maximum protection. Conveniently placed radio mute button incorporated into lower console.

12v power point and mobile phone holder built into the right hand console. Courtesy light can be operated from ground level and is illuminated for five minutes or until switched off improving operator access at night. Cab mounted roller blind protects operator from suns' glare through front or top screens.

**AMS – ADVANCED MANAGEMENT SYSTEM**

Four selectable working modes link the operators control movements with the engine and hydraulic systems to maximise productivity and efficiency.

- A (Auto)** Up to 100% engine power and 100% flow. Gives variable power and speed depending on the operator's input, matching the demand for output and efficiency to the job. Power boost is automatically activated in this mode should hard conditions be encountered. Auto idle cuts in after a period of inactivity (between 5 and 30 seconds as set by the operator)
- E (Economy)** 80% engine power. 95% of hydraulic flow maximises economy while maintaining excellent output.
- P (Precision)** 55% engine power. 90% of hydraulic flow for fine control of grading operations.
- L (Lifting)** 55% engine power. 63% of hydraulic flow with permanent power boost for maximum lifting power and control.

The Auto mode allows the AMS processor to select the optimum operational performance to match the demands of the job while the three alternative modes give precise matching of application when specific tasks are undertaken.

The adjustable position monitor mounted on the front right hand pillar of the cab gives the operator a constant read out of mode, tracking range, operating temperature and a host of other information, while retaining excellent visibility of the monitor and the job being carried out.

The required flow for hammer applications can be set and stored in the AMS memory and is automatically activated whenever the hammer pedal is depressed.

A maintenance indicator warns of imminent service needs, and all servicing and basic checks can be carried out using only the in cab display.

**STANDARD EXCAVATING BUCKETS**

All buckets are JCB – Esco fully welded steel, with sealed, hardened steel pivot pins and replaceable wear parts.

Max Width mm (in.)	Capacity (SAE heaped) cu.m (cu.yd)	Weight kg (lb)
600 (24)	0.32 (0.42)	369 (814)
750 (30)	0.43 (0.56)	423 (933)
900 (36)	0.55 (0.72)	468 (1032)
1000 (40)	0.63 (0.82)	507 (1118)
1100 (44)	0.72 (0.94)	537 (1184)
1200 (48)	0.80 (1.05)	576 (1270)

**SERVICE CAPACITIES**

	litres	UK gal
Fuel tank	253	56
Engine coolant	21	4.62
Engine oil	15	3.30
Swing reduction gear	2.2	0.5
Hydraulic system	124	27.3
Hydraulic tank	73	16.0
Transmission	2.5	0.55
Axle differentials (each)	Rear 12, Front 14	Rear 2.6, Front 3
Axle hubs (each)	2.0	0.5



STANDARD EQUIPMENT

Engine fan guard; Cold start pre-heat; Auto engine warm up; Double element air cleaner; Heavy duty alternator; Electrics isolator; Heavy-duty batteries; Cab & engine soundproofing; Cab heater & screen demister; Tinted glass; Interior light; Coat hook; 12V power socket; Ashtray; Operator's storage box; Removable floor mat; Windscreen wash/wipe; Plug-in power socket; Automatic power boost; Auto-idle; One-touch engine speed control; Hydraulic cushion control; Plexus hydraulic oil filtration; HSP pressure test points; Auxiliary pipework mounting brackets; Work lights – boom & mainframe mounted; Upper structure under covers; Swing system cover; External mirrors; Handrail & non slip walk ways; Quick connect engine oil drain pipe; Front screen blind; Quick connect fuel tank drain pipe; Hinged engine under cover; Single point greasing system.

OPTIONAL EQUIPMENT

Hose burst check valves & overload warning system; Tipping link mounted lift points; General purpose buckets; Ditch/grading buckets; Quickhitch buckets; Hydraulic hammers; Auxiliary pipework (full and low flow); Climate control; Cab mounted & rear work lights; Rotating beacon; Rain guard; Biodegradable oil; Air suspension seat with heated pad and lumbar support adjustment; Electric refuelling pump; Lower screen wiper; Radio cassette player; Cruise control.

OPERATING WEIGHTS

Chassis					
	12885kg (28405lb)	13325kg (29375lb)	13765kg (30345lb)	14305kg (31540lb)	14645kg (32290lb)
	13385kg (29510lb)	13825kg (30480lb)	14265kg (31450lb)	14805kg (32640lb)	15145kg (33390lb)

Machine equipped with excavating bucket and dual wheels. For single wheels subtract 400kg (880lb).



**LIFT CAPACITIES – Dipper Length: 2.10m, 4.70m Monoboom, Front dozer, No bucket.**
**JSI45W MONO**

Reach	1.5m (4ft 11in)		3m (9ft 10in)		4.5m (14ft 9in)		6m (19ft 8in)		7.5m (24ft 7in)		Capacity at Max Reach			
													mm	
Load Point Ht.	kg	kg	kg	kg	kg	kg	kg	kg	kg	kg	kg	kg	mm	
7.5m (24.7ft)			3550*	3550*								3580*	3580*	3052
6.0m (19.8ft)					2990*	2990*						2960*	2960*	5044
4.5m (14.9ft)			3550*	3550*	3140*	3140*	3070*	2640				2710*	2580	6069
3.0m (9.10ft)			5540*	5540*	3800*	3800*	3220*	2590				2680*	2230	6603
1.5m (4.11ft)					4570*	3730	3520*	2500				2820*	2110	6766
0m			6120*	6120*	5030*	3600	3730*	2440				3140*	2150	6587
- 1.5m (- 4.11ft)	5470*	5470*	7410*	6510	5000*	3560	3560*	2430				3520*	2420	6033
- 3.0m (- 9.10ft)			6250*	6250*	4230*	3630						3600*	3190	4979

**LIFT CAPACITIES – Dipper Length: 2.10m, 4.70m Monoboom, Rear stabilisers, No bucket.**
**JSI45W MONO**

Reach	1.5m (4ft 11in)		3m (9ft 10in)		4.5m (14ft 9in)		6m (19ft 8in)		7.5m (24ft 7in)		Capacity at Max Reach			
													mm	
Load Point Ht.	kg	kg	kg	kg	kg	kg	kg	kg	kg	kg	kg	kg	mm	
7.5m (24.7ft)			3550*	3550*								3580*	3580*	3052
6.0m (19.8ft)					2990*	2990*						2960*	2960*	5044
4.5m (14.9ft)			3550*	3550*	3140*	3140*	3070*	3070*				2710*	2710*	6069
3.0m (9.10ft)			5540*	5540*	3800*	3800*	3220*	3040				2680*	2620	6603
1.5m (4.11ft)					4570*	4440	3520*	2950				2820*	2480	6766
0m			6120*	6120*	5030*	4300	3730*	2880				3140*	2540	6587
- 1.5m (- 4.11ft)	5470*	5470*	7410*	7410*	5000*	4260	3560*	2880				3520*	2860	6033
- 3.0m (- 9.10ft)			6250*	6250*	4230*	4230						3600*	3600*	4979

**LIFT CAPACITIES – Dipper Length: 2.10m, 4.70m Monoboom, Front dozer, Rear stabilisers, No bucket.**
**JSI45W MONO**

Reach	1.5m (4ft 11in)		3m (9ft 10in)		4.5m (14ft 9in)		6m (19ft 8in)		7.5m (24ft 7in)		Capacity at Max Reach			
													mm	
Load Point Ht.	kg	kg	kg	kg	kg	kg	kg	kg	kg	kg	kg	kg	mm	
7.5m (24.7ft)			3550*	3550*								3580*	3580*	3052
6.0m (19.8ft)					2990*	2990*						2960*	2960*	5044
4.5m (14.9ft)			3550*	3550*	3140*	3140*	3070*	3070*				2710*	2710	6069
3.0m (9.10ft)			5540*	5540*	3800*	3800*	3220*	3220*				2680*	2680*	6603
1.5m (4.11ft)					4570*	4570*	3520*	3520*				2820*	2820*	6766
0m			6120*	6120*	5030*	5030*	3730*	3700				3140*	3140*	6587
- 1.5m (- 4.11ft)	5470*	5470*	7410*	7410*	5000*	5000*	3560*	3560*				3520*	3520*	6033
- 3.0m (- 9.10ft)			6250*	6250*	4230*	4230*						3600*	3600*	4979

Lift capacity front and rear.

Lift capacity full circle.

**Notes:**

1. For lifting capacity including bucket, subtract total weight of bucket or bucket and quickhitch from above values.
2. Lifting capacities are based on ISO 10567, that is: 75% of minimum tipping load or 87% of hydraulic lift capacity, whichever is the less. Lifting capacities marked\* are based on hydraulic capacity.
3. Lift capacities assume that the machine is on firm, level ground.
4. Lift capacities may be limited by local regulations. Please refer to your dealer.



**LIFT CAPACITIES – Dipper Length: 2.10m, 4.70m Monoboom, Front stabiliser, Rear stabiliser, No bucket.**
**JSI45W MONO**

Reach	1.5m (4ft 11in)		3m (9ft 10in)		4.5m (14ft 9in)		6m (19ft 8in)		7.5m (24ft 7in)		Capacity at Max Reach			
													mm	
Load Point Ht.	kg	kg	kg	kg	kg	kg	kg	kg	kg	kg	kg	kg	mm	
7.5m (24.7ft)			3550*	3550*								3580*	3580*	3052
6.0m (19.8ft)					2990*	2990*						2960*	2960*	5044
4.5m (14.9ft)			3550*	3550*	3140*	3140*	3070*	3070*				2710*	2710*	6069
3.0m (9.10ft)			5540*	5540*	3800*	3800*	3220*	3220*				2680*	2680*	6603
1.5m (4.11ft)					4570*	4570*	3520*	3520*				2820*	2820*	6766
0m			6120*	6120*	5030*	5030*	3730*	3730*				3140*	3140*	6587
- 1.5m (- 4.11ft)	5470*	5470*	7410*	7410*	5000*	5000*	3560*	3560*				3520*	3520*	6033
- 3.0m (- 9.10ft)			6250*	6250*	4230*	4230*						3600*	3600*	4979

**LIFT CAPACITIES – Dipper Length: 2.50m, 4.70m Monoboom, Front dozer, No bucket.**
**JSI45W MONO**

Reach	1.5m (4ft 11in)		3m (9ft 10in)		4.5m (14ft 9in)		6m (19ft 8in)		7.5m (24ft 7in)		Capacity at Max Reach			
													mm	
Load Point Ht.	kg	kg	kg	kg	kg	kg	kg	kg	kg	kg	kg	kg	mm	
7.5m (24.7ft)												2960*	2960	3828
6.0m (19.8ft)					2900*	2900*						2370*	2370*	5539
4.5m (14.9ft)					3150*	3150*	3110*	2680				2200*	2200*	6483
3.0m (9.10ft)			5410*	5410*	3920*	3920*	3370*	2610				2180*	2060	6984
1.5m (4.11ft)			7460*	6780	4840*	3770	3760*	2520				2290*	1950	7136
0m			6840*	6510	5480*	3610	4070*	2440				2540*	1990	6965
- 1.5m (- 4.11ft)	5120*	5120*	8450*	6480	5600*	3550	4080*	2410				3060*	2200	6442
- 3.0m (- 9.10ft)	9290*	9290*	7440*	6580	5040*	3590						3840*	2780	5467

**LIFT CAPACITIES – Dipper Length: 2.50m, 4.70m Monoboom, Rear stabilisers, No bucket.**
**JSI45W MONO**

Reach	1.5m (4ft 11in)		3m (9ft 10in)		4.5m (14ft 9in)		6m (19ft 8in)		7.5m (24ft 7in)		Capacity at Max Reach			
													mm	
Load Point Ht.	kg	kg	kg	kg	kg	kg	kg	kg	kg	kg	kg	kg	mm	
7.5m (24.7ft)												3080*	3080*	3821
6.0m (19.8ft)					2620*	2620*						2470*	2470*	5536
4.5m (14.9ft)					2840*	2840*	2790*	2790*				2290*	2290*	6483
3.0m (9.10ft)			4870*	4870*	3520*	3520*	3030*	3030*				2270*	2270*	6985
1.5m (4.11ft)			7020*	7020*	4350*	4350*	3380*	2970				2380*	2300	7139
0m			6760*	6760*	4920*	4310	3660*	2880				3630*	2350	6970
- 1.5m (- 4.11ft)	5050*	5050*	7610*	7610*	5040*	4250	3660*	2860				3610*	2600	6449
- 3.0m (- 9.10ft)	9270*	9270*	6690*	6690*	4530*	4290						3440*	3280	5478

Lift capacity front and rear.

Lift capacity full circle.

**Notes:**

1. For lifting capacity including bucket, subtract total weight of bucket or bucket and quickhitch from above values.
2. Lifting capacities are based on ISO 10567, that is: 75% of minimum tipping load or 87% of hydraulic lift capacity, whichever is the less. Lifting capacities marked\* are based on hydraulic capacity.
3. Lift capacities assume that the machine is on firm, level ground.
4. Lift capacities may be limited by local regulations. Please refer to your dealer.

**LIFT CAPACITIES – Dipper Length: 2.50m, 4.70m Monoboom, Front dozer, Rear stabiliser, No bucket.**
**JS145W MONO**

Reach	1.5m (4ft 11in)		3m (9ft 10in)		4.5m (14ft 9in)		6m (19ft 8in)		7.5m (24ft 7in)		Capacity at Max Reach				
													kg	kg	mm
Load Point Ht.	kg	kg													
7.5m (24.7ft)													3080*	3080*	3821
6.0m (19.8ft)					2620*	2620*							2470*	2470*	5536
4.5m (14.9ft)					2840*	2840*	2790*	2790*					2290*	2290*	6483
3.0m (9.10ft)			4870*	4870*	3520*	3520*	3030*	3030*					2270*	2270*	6985
1.5m (4.11ft)			7020*	7020*	4350*	4350*	3380*	3380*					2380*	2380*	7139
0m			6760*	6760*	4920*	4920*	3660*	3660*					2630*	2630*	6970
- 1.5m (- 4.11ft)	5050*	5050*	7610*	7610*	5040*	5040*	3660*	3660*					3160*	3160*	6449
- 3.0m (- 9.10ft)	9270*	9270*	6690*	6690*	4530*	4530*							3440*	3440*	5478

**LIFT CAPACITIES – Dipper Length: 2.50m, 4.70m Monoboom, Front stabiliser, Rear stabiliser, No bucket.**
**JS145W MONO**

Reach	1.5m (4ft 11in)		3m (9ft 10in)		4.5m (14ft 9in)		6m (19ft 8in)		7.5m (24ft 7in)		Capacity at Max Reach				
													kg	kg	mm
Load Point Ht.	kg	kg													
7.5m (24.7ft)													3080*	3080*	3821
6.0m (19.8ft)					2620*	2620*							2470*	2470*	5536
4.5m (14.9ft)					2840*	2840*	2790*	2790*					2290*	2290*	6483
3.0m (9.10ft)			4870*	4870*	3520*	3520*	3030*	3030*					2270*	2270*	6985
1.5m (4.11ft)			7020*	7020*	4350*	4350*	3380*	3380*					2380*	2380*	7139
0m			6760*	6760*	4920*	4920*	3660*	3660*					2630*	2630*	6970
- 1.5m (- 4.11ft)	5050*	5050*	7610*	7610*	5040*	5040*	3660*	3660*					3160*	3160*	6449
- 3.0m (- 9.10ft)	9270*	9270*	6690*	6690*	4530*	4530*							3440*	3440*	5478

**LIFT CAPACITIES – Dipper Length: 3.00m, 4.70m Monoboom, Front dozer, No bucket.**
**JS145W MONO**

Reach	1.5m (4ft 11in)		3m (9ft 10in)		4.5m (14ft 9in)		6m (19ft 8in)		7.5m (24ft 7in)		Capacity at Max Reach				
													kg	kg	mm
Load Point Ht.	kg	kg													
7.5m (24.7ft)													2580*	2580*	4622
6.0m (19.8ft)					2170*	2170*	2510*	2510*					2170*	2170*	6113
4.5m (14.9ft)					2430*	2430*	2470*	2470*					2040*	2040*	6980
3.0m (9.10ft)			4020*	4020*	3120*	3120*	2750*	2620					2040*	1860	7448
1.5m (4.11ft)			6280*	6280*	4000*	3790	3150*	2510	2580*	1800			2130*	1760	7593
0m			7510*	6480	4700*	3590	3500*	2410					2340*	1780	7434
- 1.5m (- 4.11ft)	4580*	4580*	7670*	6370	4970*	3490	3640*	2360					2760*	1940	6949
- 3.0m (- 9.10ft)	7870*	7870*	7050*	6430	4710*	3500	3260*	2380					3200*	2360	6060
- 4.5m (- 14.9ft)			5340*	5340*	3320*	3320*							3280*	3280*	4528

Lift capacity front and rear.

Lift capacity full circle.

**Notes:**

1. For lifting capacity including bucket, subtract total weight of bucket or bucket and quickhitch from above values.
2. Lifting capacities are based on ISO 10567, that is: 75% of minimum tipping load or 87% of hydraulic lift capacity, whichever is the less. Lifting capacities marked\* are based on hydraulic capacity.
3. Lift capacities assume that the machine is on firm, level ground.
4. Lift capacities may be limited by local regulations. Please refer to your dealer.

**LIFT CAPACITIES – Dipper Length: 3.00m, 4.70m Monoboom, Rear stabilisers, No bucket.**
**JSI45W MONO**

Reach	1.5m (4ft 11in)		3m (9ft 10in)		4.5m (14ft 9in)		6m (19ft 8in)		7.5m (24ft 7in)		Capacity at Max Reach			
													kg	kg
Load Point Ht.	kg	kg	kg	kg	kg	kg	kg	kg	kg	kg	kg	kg	kg	mm
7.5m (24.7ft)					2580*	2580*						2580*	2580*	4622
6.0m (19.8ft)					2170*	2170*	2510*	2510*				2170*	2170*	6113
4.5m (14.9ft)					2430*	2430*	2470*	2470*				2040*	2040*	6980
3.0m (9.10ft)			4020*	4020*	3120*	3120*	2750*	2750*				2040*	2040*	7448
1.5m (4.11ft)			6280*	6280*	4000*	4000*	3150*	2960	2580*	2120		2130*	2080	7593
0m			7510*	7510*	4700*	4290	3500	2860				2340*	2110	7434
- 1.5m (- 4.11ft)	4580*	4580*	7670*	7670*	4970*	4190	3640*	2800				2760*	2300	6949
- 3.0m (- 9.10ft)	7870*	7870*	7050*	7050*	4710*	4200	3260*	2830				3200*	2800	6060
- 4.5m (- 14.9ft)			5340*	5340*		3320*	3320*					3280*	3280*	4528

**LIFT CAPACITIES – Dipper Length: 3.00m, 4.70m Monoboom, Front dozer, Rear stabilisers, No bucket.**
**JSI45W MONO**

Reach	1.5m (4ft 11in)		3m (9ft 10in)		4.5m (14ft 9in)		6m (19ft 8in)		7.5m (24ft 7in)		Capacity at Max Reach			
													kg	kg
Load Point Ht.	kg	kg	kg	kg	kg	kg	kg	kg	kg	kg	kg	kg	kg	mm
7.5m (24.7ft)					2580*	2580*						2580*	2580*	4622
6.0m (19.8ft)					2170*	2170*	2510*	2510*				2170*	2170*	6113
4.5m (14.9ft)					2430*	24360*	2470*	2470*				2040*	2040*	6980
3.0m (9.10ft)			4020*	4020*	3120*	3120*	2750*	2750*				2040*	2040	7448
1.5m (4.11ft)			6280*	6280*	4000*	4000*	3150*	3150*	2580*	2580*		2130*	2130*	7593
0m			7510*	7510*	4700*	4700*	3500*	3500*				2340*	2340*	7434
- 1.5m (- 4.11ft)	4580*	4580*	7670*	7670*	4970*	4970*	3640*	3620				2760*	2760*	6949
- 3.0m (- 9.10ft)	7870*	7870*	7050*	7050*	4710*	4710*	3260*	3260*				3200*	3200*	6060
- 4.5m (- 14.9ft)			5340*	5340*	3320*	3320*						3280*	3280	4528

**LIFT CAPACITIES – Dipper Length: 3.00m, 4.70m Monoboom, Front stabilisers, Rear stabilisers, No bucket.**
**JSI45W MONO**

Reach	1.5m (4ft 11in)		3m (9ft 10in)		4.5m (14ft 9in)		6m (19ft 8in)		7.5m (24ft 7in)		Capacity at Max Reach			
													kg	kg
Load Point Ht.	kg	kg	kg	kg	kg	kg	kg	kg	kg	kg	kg	kg	kg	mm
7.5m (24.7ft)					2580*	2580*						2580*	2580*	4622
6.0m (19.8ft)					2170*	2170*	2510*	2510*				2170*	2170*	6113
4.5m (14.9ft)					2430*	2430*	2470*	2470*				2040*	2040*	6980
3.0m (9.10ft)			4020*	4020*	3120*	3120*	2750*	2750*				2040*	2040*	7448
1.5m (4.11ft)			6280*	6280*	4000*	4000*	3150*	3150*	2580*	2580*		2130*	2130*	7593
0m			7510*	7510*	4700*	4700*	3500*	3500*				2340*	2340*	7434
- 1.5m (- 4.11ft)	4580*	4580*	7670*	7670*	4970*	4970*	3640*	3620				2760*	2760*	6949
- 3.0m (- 9.10ft)	7870*	7870*	7050*	7050*	4710*	4710*	3260*	3260*				3200*	3200*	6060
- 4.5m (- 14.9ft)			5340*	5340*	3320*	3320*						3280*	3280	4528



Lift capacity front and rear.



Lift capacity full circle.

**Notes:**

1. For lifting capacity including bucket, subtract total weight of bucket or bucket and quickhitch from above values.
2. Lifting capacities are based on ISO 10567, that is: 75% of minimum tipping load or 87% of hydraulic lift capacity, whichever is the less. Lifting capacities marked\* are based on hydraulic capacity.
3. Lift capacities assume that the machine is on firm, level ground.
4. Lift capacities may be limited by local regulations. Please refer to your dealer.

**LIFT CAPACITIES – Dipper Length: 2.10m, 5.00m T.A.B., Front dozer, No bucket.**
**JSI45W T.A.B.**

Reach	1.5m (4ft 11in)		3m (9ft 10in)		4.5m (14ft 9in)		6m (19ft 8in)		7.5m (24ft 7in)		Capacity at Max Reach				
													kg	kg	mm
Load Point Ht.	kg	kg											kg	kg	mm
7.5m (24.7ft)													3420*	3420*	3866
6.0m (19.8ft)					2870*	2870*							3010*	2960	5567
4.5m (14.9ft)			3850*	3850*	3140*	3140*	2870*	2640					2730*	2290	6509
3.0m (9.10ft)					3800*	3800*	3090*	2550					2650*	2000	7009
1.5m (4.11ft)					4500*	3640	3390*	2450					2700*	1900	7163
0m					4880*	3500	3590*	2380					2900*	1940	6994
- 1.5m (- 4.11ft)			6990*	6390	4820*	3470	3510*	2370					3090*	2160	6476
- 3.0m (- 9.10ft)					4180*	3550							3310*	2850	5334

**LIFT CAPACITIES – Dipper Length: 2.10m, 5.00m T.A.B., Rear stabilisers, No bucket.**
**JSI45W T.A.B.**

Reach	1.5m (4ft 11in)		3m (9ft 10in)		4.5m (14ft 9in)		6m (19ft 8in)		7.5m (24ft 7in)		Capacity at Max Reach				
													kg	kg	mm
Load Point Ht.	kg	kg	kg	kg	kg	kg	kg	kg	kg	kg			kg	kg	mm
7.5m (24.7ft)													3420*	3420*	3866
6.0m (19.8ft)					2870*	2870*							3010*	3010*	5567
4.5m (14.9ft)			3850*	3850*	3140*	3140*	2870*	2870*					2730*	2730*	6509
3.0m (9.10ft)					3800*	3800*	3090*	3090*					2650*	2470	7009
1.5m (4.11ft)					4500*	4500*	3390*	3030					2700*	2350	7163
0m					4880*	4390	3590*	2950					2900*	2410	6994
- 1.5m (- 4.11ft)			6990*	6990*	4820*	4360	3510*	2940					3090*	2680	6476
- 3.0m (- 9.10ft)					4180*	4180*							3310*	3310*	5334

**LIFT CAPACITIES – Dipper Length: 2.10m, 5.00m T.A.B., Front dozer, Rear stabilisers, No bucket.**
**JSI45W T.A.B.**

Reach	1.5m (4ft 11in)		3m (9ft 10in)		4.5m (14ft 9in)		6m (19ft 8in)		7.5m (24ft 7in)		Capacity at Max Reach				
													kg	kg	mm
Load Point Ht.	kg	kg	kg	kg	kg	kg	kg	kg	kg	kg			kg	kg	mm
7.5m (24.7ft)													3420*	3420*	3866
6.0m (19.8ft)					2870*	2870*							3010*	3010*	5567
4.5m (14.9ft)			3850*	3850*	3140*	3140*	2870*	2870*					2730*	2730*	6509
3.0m (9.10ft)					3800*	3800*	3090*	3090*					2650*	2650*	7009
1.5m (4.11ft)					4500*	4500*	3390*	3390*					2700*	2700*	7163
0m					4880*	4880*	3590*	3590*					2900*	2900*	6994
- 1.5m (- 4.11ft)			6990*	6990*	4820*	4820*	3510*	3510*					3090*	3090*	6476
- 3.0m (- 9.10ft)					4180*	4180*							3310*	3310*	5334

Lift capacity front and rear.

Lift capacity full circle.

**Notes:**

1. For lifting capacity including bucket, subtract total weight of bucket or bucket and quickhitch from above values.
2. Lifting capacities are based on ISO 10567, that is: 75% of minimum tipping load or 87% of hydraulic lift capacity, whichever is the less. Lifting capacities marked\* are based on hydraulic capacity.
3. Lift capacities assume that the machine is on firm, level ground.
4. Lift capacities may be limited by local regulations. Please refer to your dealer.

**LIFT CAPACITIES – Dipper Length: 2.10m, 5.00m T.A.B., Front stabilisers, Rear stabilisers, No bucket.**
**JSI45W T.A.B.**

Reach	1.5m (4ft 11in)		3m (9ft 10in)		4.5m (14ft 9in)		6m (19ft 8in)		7.5m (24ft 7in)		Capacity at Max Reach			
													mm	
Load Point Ht.	kg	kg	kg	kg	kg	kg	kg	kg	kg	kg	kg	kg	mm	
7.5m (24.7ft)												3420*	3420*	3866
6.0m (19.8ft)					2870*	2870*						3010*	2960	5567
4.5m (14.9ft)			3850*	3850*	3140*	3140*	2870*	2870*				2730*	2730	6509
3.0m (9.10ft)					3800*	3800*	3090*	3090*				2650*	2650*	7009
1.5m (4.11ft)					4500*	4500*	3390*	3390*				2700*	2700*	7163
0m					4880*	4880*	3590*	3590*				2900*	2900*	6994
- 1.5m (- 4.11ft)			6990*	6990*	4820*	4820*	3510*	3510*				3090*	3090*	6476
- 3.0m (- 9.10ft)					4180*	4180*						3310*	3310*	5334

**LIFT CAPACITIES – Dipper Length: 2.50m, 5.00m T.A.B., Front dozer, No bucket.**
**JSI45W T.A.B.**

Reach	1.5m (4ft 11in)		3m (9ft 10in)		4.5m (14ft 9in)		6m (19ft 8in)		7.5m (24ft 7in)		Capacity at Max Reach			
													mm	
Load Point Ht.	kg	kg	kg	kg	kg	kg	kg	kg	kg	kg	kg	kg	mm	
7.5m (24.7ft)					3300*	3300*						3040*	3040*	4558
6.0m (19.8ft)					2850*	2850*	2860*	2650				2460*	2460*	6065
4.5m (14.9ft)					3190*	3190*	2960*	2660				2250*	2060	6938
3.0m (9.10ft)					3940*	3920	3250*	2560				2190*	1820	7409
1.5m (4.11ft)					4780*	3640	3630*	2440	2740*	1760		2230*	1740	7555
0m			3700*	3700*	5310*	3470	3910*	2350				2390*	1770	7395
- 1.5m (- 4.11ft)			7150*	6280	5380*	3420	3940*	2320				2730*	1950	6907
- 3.0m (- 9.10ft)			7020*	6410	4880*	3470	3250*	2400				3220*	2390	6012

**LIFT CAPACITIES – Dipper Length: 2.50m, 5.00m T.A.B., Rear stabilisers, No bucket.**
**JSI45W T.A.B.**

Reach	1.5m (4ft 11in)		3m (9ft 10in)		4.5m (14ft 9in)		6m (19ft 8in)		7.5m (24ft 7in)		Capacity at Max Reach			
													mm	
Load Point Ht.	kg	kg	kg	kg	kg	kg	kg	kg	kg	kg	kg	kg	mm	
7.5m (24.7ft)					3300*	3300*						3040*	3040*	4558
6.0m (19.8ft)					2850*	2850*	2860*	2860*				2460*	2460*	6065
4.5m (14.9ft)			3190*	3190*	2960*	2960*						2250*	2250*	6938
3.0m (9.10ft)					3940*	3940*	3250*	3020				2190*	2160	7409
1.5m (4.11ft)					4780*	4370	3630*	2900	2740*	2090		2230*	2070	7555
0m			3700*	3700*	5310*	4180	3910*	2800				2390*	2110	7395
- 1.5m (- 4.11ft)			7150*	7150*	5380*	4130	3940*	2770				2730*	2320	6907
- 3.0m (- 9.10ft)			7020*	7020*	4880*	4180	3250*	2850				3220*	2850	6012

Lift capacity front and rear.

Lift capacity full circle.

**Notes:**

1. For lifting capacity including bucket, subtract total weight of bucket or bucket and quickhitch from above values.
2. Lifting capacities are based on ISO 10567, that is: 75% of minimum tipping load or 87% of hydraulic lift capacity, whichever is the less. Lifting capacities marked\* are based on hydraulic capacity.
3. Lift capacities assume that the machine is on firm, level ground.
4. Lift capacities may be limited by local regulations. Please refer to your dealer.

**LIFT CAPACITIES – Dipper Length: 2.50m, 5.00m T.A.B., Front dozer, Rear stabilisers, No bucket.**
**JSI45W T.A.B.**

Reach	1.5m (4ft 11in)		3m (9ft 10in)		4.5m (14ft 9in)		6m (19ft 8in)		7.5m (24ft 7in)		Capacity at Max Reach			
													mm	
Load Point Ht.	kg	kg	kg	kg	kg	kg	kg	kg	kg	kg	kg	kg		
7.5m (24.7ft)					3300*	3300*						3040*	3040*	4558
6.0m (19.8ft)					2850*	2850*	2860*	2860*				2460*	2460*	6065
4.5m (14.9ft)					3190*	3190*	2960*	2960*				2250*	2250*	6938
3.0m (9.10ft)					3940*	3940*	3250*	3250*				2190*	2190*	7409
1.5m (4.11ft)					4780*	4780*	3630*	3630*	2740*	2690		2230*	2230*	7555
0m			3700*	3700*	5310*	5310*	3910*	3630				2390*	2390*	7395
- 1.5m (- 4.11ft)			7150*	7150*	5380*	5380*	3940*	3600				2730*	2730*	6907
- 3.0m (- 9.10ft)			7020*	7020*	4880*	4880*	3250*	3250*				3220*	3220*	6012

**LIFT CAPACITIES – Dipper Length: 2.50m, 5.00m T.A.B., Front stabilisers, Rear stabilisers, No bucket.**
**JSI45W T.A.B.**

Reach	1.5m (4ft 11in)		3m (9ft 10in)		4.5m (14ft 9in)		6m (19ft 8in)		7.5m (24ft 7in)		Capacity at Max Reach			
													mm	
Load Point Ht.	kg	kg	kg	kg	kg	kg	kg	kg	kg	kg	kg	kg		
7.5m (24.7ft)					3300*	3300*						3040*	3040*	4558
6.0m (19.8ft)					2850*	2850*	2860*	2860*				2460*	2460*	6065
4.5m (14.9ft)					3190*	3190*	2960*	2960*				2250*	2250*	6938
3.0m (9.10ft)					3940*	3940*	3250*	3250*				2190*	2190*	7409
1.5m (4.11ft)					4780*	4780*	3630*	3630*	2740*	2740*		2230*	2230*	7555
0m			3700*	3700*	5310*	5310*	3910*	3910*				2390*	2390*	7395
- 1.5m (- 4.11ft)			7150*	7150*	5380*	5380*	3940*	3940*				2730*	2730*	6907
- 3.0m (- 9.10ft)			7020*	7020*	488*	4880*	3250*	3250*				3220*	3220*	6012

**LIFT CAPACITIES – Dipper Length: 3.00m, 5.00m T.A.B., Front dozer, No bucket.**
**JSI45W T.A.B.**

Reach	1.5m (4ft 11in)		3m (9ft 10in)		4.5m (14ft 9in)		6m (19ft 8in)		7.5m (24ft 7in)		Capacity at Max Reach			
													mm	
Load Point Ht.	kg	kg	kg	kg	kg	kg	kg	kg	kg	kg	kg	kg		
7.5m (24.7ft)					2640*	2640*						2640*	2640*	5315
6.0m (19.8ft)					2440*	2440*	2590*	2590*				2230*	2230*	6650
4.5m (14.9ft)					2800*	2800*	2670*	2670*				2080*	1830	7453
3.0m (9.10ft)					3550*	3550*	3000*	2570	2760*	1800		2030*	1640	7893
1.5m (4.11ft)					4440*	3670	3420*	2430	2920*	1740		2080*	1560	8030
0m					5100*	3450	3770*	2320	3050*	1690		2210*	1580	7880
- 1.5m (- 4.11ft)	3060*	3060*	6650*	6150	5330*	3350	3900*	2260				2490*	1720	7425
- 3.0m (- 9.10ft)			7430*	6240	5050*	3370	3620*	2290				3020*	2050	6601

Lift capacity front and rear.

Lift capacity full circle.

**Notes:**

1. For lifting capacity including bucket, subtract total weight of bucket or bucket and quickhitch from above values.
2. Lifting capacities are based on ISO 10567, that is: 75% of minimum tipping load or 87% of hydraulic lift capacity, whichever is the less. Lifting capacities marked\* are based on hydraulic capacity.
3. Lift capacities assume that the machine is on firm, level ground.
4. Lift capacities may be limited by local regulations. Please refer to your dealer.

**LIFT CAPACITIES – Dipper Length: 3.00m, 5.00m T.A.B., Rear stabilisers, No bucket.**
**JSI45W T.A.B.**

Reach	1.5m (4ft 11in)		3m (9ft 10in)		4.5m (14ft 9in)		6m (19ft 8in)		7.5m (24ft 7in)		Capacity at Max Reach		
													mm
Load Point Ht.	kg	kg	kg	kg	kg	kg	kg	kg	kg	kg	kg	kg	mm
7.5m (24.7ft)					2640*	2640*					2640*	2640*	5315
6.0m (19.8ft)					2440*	2440*	2590*	2590*			2230*	2230*	6650
4.5m (14.9ft)					2800*	2800*	2670*	2670*			2080*	2080*	7453
3.0m (9.10ft)					3550*	3550*	3000*	3000*	2760*	2220	2030*	2030*	7893
1.5m (4.11ft)					4440*	4440*	3420*	3010	2920*	2170	2080*	1950	8030
0m					5100*	4340	3770*	2900	3050*	2120	2210*	1980	7880
- 1.5m (- 4.11ft)	3060*	3060*	6650*	6650*	5330*	4240	3900*	2840			2490*	2150	7425
- 3.0m (- 9.10ft)			7430*	7430*	5050*	4260	3620*	2860			3020*	2550	6601

**LIFT CAPACITIES – Dipper Length: 3.00m, 5.00m T.A.B., Front dozer, Rear stabilisers, No bucket.**
**JSI45W T.A.B.**

Reach	1.5m (4ft 11in)		3m (9ft 10in)		4.5m (14ft 9in)		6m (19ft 8in)		7.5m (24ft 7in)		Capacity at Max Reach		
													mm
Load Point Ht.	kg	kg	kg	kg	kg	kg	kg	kg	kg	kg	kg	kg	mm
7.5m (24.7ft)					2640*	2640*					2640*	2640*	5315
6.0m (19.8ft)					2440*	2440*	2590*	2590*			2230*	2230*	6650
4.5m (14.9ft)					2800*	2800*	2670*	2670*			2080*	2080*	7453
3.0m (9.10ft)					3550*	3550*	3000*	3000*	2760*	2730	2030*	2030*	7893
1.5m (4.11ft)					4440*	4440*	3420*	3420*	2920*	2680	2080*	2080*	8030
0m					5100*	5100*	3770*	3610	3050*	2630	2210*	2210*	7880
- 1.5m (- 4.11ft)	3060*	3060*	6650*	6650*	5330*	5330*	3900*	3550			2490*	2490*	7425
- 3.0m (- 9.10ft)			7430*	7430*	5050*	5050*	3620*	3570			3020*	3020*	6601

**LIFT CAPACITIES – Dipper Length: 3.00m, 5.00m T.A.B., Front stabilisers, Rear stabilisers, No bucket.**
**JSI45W T.A.B.**

Reach	1.5m (4ft 11in)		3m (9ft 10in)		4.5m (14ft 9in)		6m (19ft 8in)		7.5m (24ft 7in)		Capacity at Max Reach		
													mm
Load Point Ht.	kg	kg	kg	kg	kg	kg	kg	kg	kg	kg	kg	kg	mm
7.5m (24.7ft)					2640*	2640*					2640*	2640*	5315
6.0m (19.8ft)					2440*	2440*	2590*	2590*			2230*	2230*	6650
4.5m (14.9ft)					2800*	2800*	2670*	2670*			2080*	2080*	7453
3.0m (9.10ft)					3550*	3550*	3000*	3000*	2760*	2760*	2030*	2030*	7893
1.5m (4.11ft)					4440*	4440*	3420*	3420*	2920*	2920*	2080*	2080*	8030
0m					5100*	5100*	3770*	3770*	3050*	2990	2210*	2210*	7880
- 1.5m (- 4.11ft)	3060*	3060*	6650*	6650*	5330*	5330*	3900*	3900*			2490*	2490*	7425
- 3.0m (- 9.10ft)			7430*	7430*	5050*	5050*	320*	3620*			3020*	3020*	6601

Lift capacity front and rear.

Lift capacity full circle.

**Notes:**

1. For lifting capacity including bucket, subtract total weight of bucket or bucket and quickhitch from above values.
2. Lifting capacities are based on ISO 10567, that is: 75% of minimum tipping load or 87% of hydraulic lift capacity, whichever is the less. Lifting capacities marked\* are based on hydraulic capacity.
3. Lift capacities assume that the machine is on firm, level ground.
4. Lift capacities may be limited by local regulations. Please refer to your dealer.

## A GLOBAL COMMITMENT TO QUALITY

JCB's total commitment to its products and customers has helped it grow from a one-man business into Britain's largest privately owned manufacturer of backhoe loaders, crawler excavators, wheeled excavators, telescopic handlers, wheeled loaders, dump trucks, rough terrain fork lifts, industrial fork lifts, mini/midi excavators, skid steer loaders, tractors and compaction equipment.

By making constant and massive investments in the latest production technology, the JCB factories have become some of the most advanced in the world.

By leading the field in innovative research and design, extensive testing and stringent quality control, JCB machines have become renowned all over the world for performance, value and reliability.

And with a global sales and service network of more than 650 dealers and agents, we aim to deliver the best customer support in the industry.

Through setting the standards by which others are judged, JCB has become one of the world's most impressive success stories.

